

PROCOM

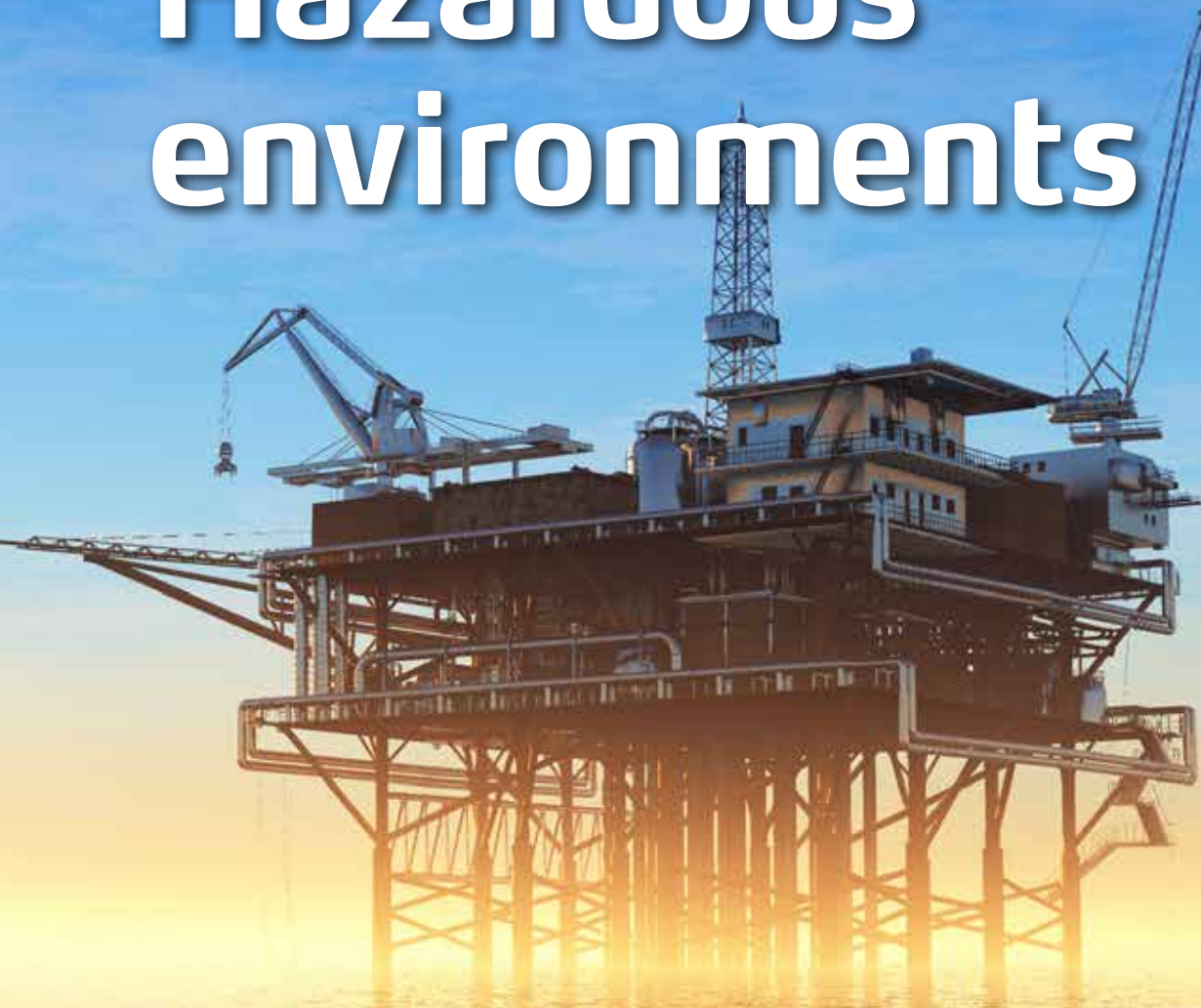

World class antenna solutions for

Hazardous environments



EX certified antennas
for professional communication

Amphenol[®]
PRIVATE NETWORKS

Procom Ex certified antennas

Safety in places where mistakes cannot be forgiven

Procom offers more than 25 different ATEX antenna types.

ATEX antennas for the Oil- and Petrochemical industry where wireless onboard communication, paging systems, ground-to-air communication, maritime VHF communication and Wi-Fi data transmission systems are in use.

Risk of explosion requires a need for ATEX certified equipment.

Demands and requirements: Radio equipment and wireless solutions are more and more common for mission-critical voice and data communication in hazardous areas like oil platforms, FPSO vessels, tankers and refineries.

Aviation



Refinery



Maritime



Oil & Gas



ATEX European Directive

Potentially explosive atmospheres

Standard regulations for equipment used inside hazardous areas with potentially explosive atmospheres is a core issue for the

European Union. Thus, they took lead in developing standards which became famous as ATEX directives (ATmosphères EXplo-

sibles). They apply to all kinds of electrical or non-electrical equipment and safety devices as well as machines and industrial facilities located within potentially explosive atmospheres. Since July 2003 it is mandatory to use devices which have an ATEX type approval all across Europe.

2014/34/EU Directive

Harmonises legal provisions of member states for devices and protection systems for designated use in potentially explosive areas. ATEX 2014

1992/92/EC Directive

Minimum requirements for improving the health and safety protection of the worker at risk from explosive atmospheres. ATEX 137

TEMPERATURE CLASSES:	
	For gases Max. surface temperature
T1	450° C
T2	300° C
T3	200° C
T4	135° C
T5	100° C
T6	85° C

EXPLOSION GROUP:	
I	Methane (mining)
IIA	such as Propane
IIB	such as Ethylene
IIC	most dangerous group (e.g. hydrogen)

DEVICE GROUP	
II	All explosive areas (except mining)
CATEGORY	
1	Can be used in zone 0 or 20
2	Can be used in Zones 1 or 21
3	Can be used in Zones 2 or 22

ATMOSPHERE	
G	Gas

TYPES OF PROTECTION	
o	oil
p	High pressure encapsulation
q	Sand encapsulation
d	Pressure resistant encapsulation
e	Increased safety
ia	Intrinsic safety (required for zone 0)
ib	Intrinsic safety (required for zone 1)
m	Encapsulation
nA	Non-sparking apparatus
s	Special protection

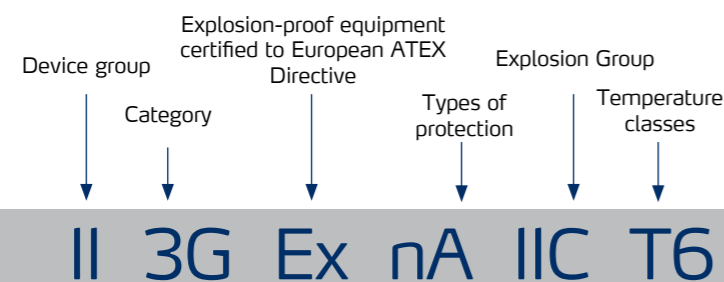

Procom Ex antennas classification



Procom Ex Antenna Portfolio

Procom offers more than 25 different ATEX antenna types. Based on the ATEX directives 2014/34/EU, the Procom product type series

CXL - Ex named below are ATEX marked and delivered with ATEX conformity. All products conform to **ATEX Class: II 3G Ex nA IIC T6**.

VHF & UHF Marine and Basestation Antennas

CXL 150-1LW-SS-Ex

ATEX certified, 0 dBd, Omnidirectional Base Station Antenna for the 138 - 175 MHz Bands.

- > Frequency range 138-175 MHz
- > Gain: 2 dBi 0 dBd
- > Bandwidth: 18-21 MHz
- > Radiation: Omnidirectional
- > Polarization: Vertical

CXL 450-1LW-SS-Ex

ATEX certified, 0 dBd, Omnidirectional Base Station and Marine Antenna for the 450 MHz Band in hazardous areas

- > Frequency range 380 - 430 MHz & 420 - 470 MHz & 460 - 510 MHz
- > Gain: 2 dBi 0 dBd
- > Bandwidth: 30 MHz
- > Radiation: Omnidirectional
- > Polarization: Vertical

MA 160-Ex

ATEX certified, End-fed Stainless Steel Dipole, Marine and Base Station Antenna for the International Maritime VHF band in Hazardous Areas.

- > Model Covering 154 - 162 MHz
- > Gain: 2 dBi 0 dBd
- > 1" Pipe Mount for installation versatility
- > Radiation: Omnidirectional
- > Polarization: Vertical

MA 450-Ex

ATEX certified, End-fed Stainless Steel Dipole, Marine and Base Station Antenna for the 450 MHz band in Hazardous Areas.

- > Model Covering 380 - 460 MHz
- > Gain: 2 dBi 0 dBd
- > Bandwidth: 20 MHz
- > 1" Pipe Mount for installation versatility
- > Radiation: Omnidirectional
- > Polarization: Vertical

Coming Soon!



Airband

CXL 130-1C-Ex

ATEX certified, 0 dBd, Omnidirectional Base Station Antenna for the International Aircraft Band.

- > Frequency range 110-140 MHz
- > Gain: 2 dBi 0 dBd
- > Bandwidth: 30 MHz
- > Radiation: Omnidirectional
- > Polarization: Vertical

CXL 130-1-Ex

ATEX certified, 0 dBd, Omnidirectional Base Station Antenna for the International Aircraft Band.

- > Frequency range 118-137 MHz
- > Gain: 2 dBi 0 dBd
- > Bandwidth: 19 MHz
- > Radiation: Omnidirectional

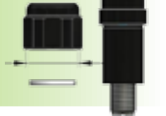

Wi-Fi

CXL 2400-3LW-SS-Ex

ATEX certified, 3 dBd, Omnidirectional Base Station and Marine Antenna for the 2400 MHz Band.

- > Frequency range within 2200 - 2700 MHz
- > Gain: 5 dBi 3 dBd
- > Bandwidth: ≥ 200 MHz @ $SWR \leq 2.0$ & ≥ 100 MHz @ $SWR \leq 2.0$ depending on model
- > Radiation: Omnidirectional
- > Polarization: Vertical

CXL 2400-1LW-SS-Ex

ATEX certified, 0 dBd, Omnidirectional Base Station and Marine Antenna for the 2400 MHz Band.

- > Frequency range within 2300 - 2700 MHz
- > Gain: 2 dBi 0 dBd
- > Bandwidth: ≥ 100 MHz @ $SWR \leq 1.5$
- > Radiation: Omnidirectional
- > Polarization: Vertical



GPS

GPS 4-Ex

Passive GPS receiving antenna for Galileo, Glonass and BeiDou navigational system.

Full hemispherical coverage due to quadrifilar helix antenna elements.

- > Antenna type: Passive quadrifilar helix antenna
- > Frequency: 1575 - 1650 MHz
- > Gain: 2 dBic 0 dBd
- > Polarization: Circular right-hand



Antenna Equipment for Hazardous Environments

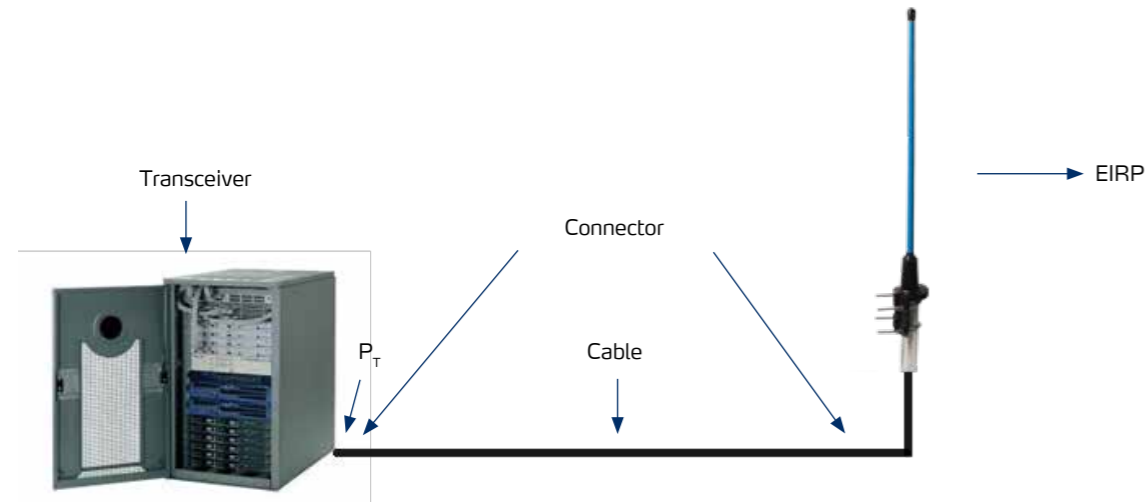

Determining the EIRP of an RF transmitting system

EIRP	Ant. Gain	Connector	Cable	Connector	P _T
	- (+ 5 dBi)	- (- 0.1 dB)	- (- 3.0 dB)	- (- 0.1 dB)	
2 W = + 33 dBm	+ 28 dBm	+ 28.1 dBm	+ 31.1 dBm	+ 31.2 dBm = 1.32 W	

Add/Deduct

TRANSMITTER POWER P_T VERSUS RADIATED POWER EIRP

Guidelines for determining the right transmitter power to fulfill the threshold power in a classified ATEX area.

Calculate the EIRP:

EIRP = Effective isotropically radiated power

P_T = Transmitter output power (dBm)

C_T = Signal loss in cable (dB)

CON_T = Signal loss in connector (dB)

G_T = Gain of the antenna (dBi)

Using this formula:

$$EIRP = P_T - CON_T - C_T + G_T$$

The EIRP is defined as the product of the power supplied to the antenna and the antenna gain.

The performance of the radio system depends on the antenna radiation, antenna gain, and of course, antenna location.

For RF with short pulses, the energy must be limited as per EN/IEC 60079-0, §6.6.1 table Transceivers radiate electromagnetic radiation which constitutes a possible ignition source in hazardous areas.

Note: The EIRP must not exceed the threshold power in a certain equipment group.

EQUIPMENT GROUP	THRESHOLD POWER [W]
Group IIA	6 W
Group IIB	3.5 W
Group IIC	2 W

RISK OF EXPLOSION REQUIRES A NEED FOR ATEX CERTIFIED EQUIPMENT.

Demands and requirements:

Radio equipment and wireless solutions are more and more common for mission-critical voice and data communication in hazardous areas like oil platforms, FPSO vessels, tankers and refineries. In some installations it is difficult to place the equipment in safe areas because of narrow space and confined rooms.

In that case the communication equipment will, for some parts, be located in the classified area. Base station transceivers will be located in a safe area, because of the need for high power, but cable and antennas will sometimes be installed in, or pass through, classified areas, for example Zone 1 or Zone 2 where the equipment has to be ATEX certified.

Onboard a ship or an oil platform it can be difficult to find a safe and non-classified location. Typically antenna equipment will be installed in safe areas, but if space is limited, it may be impossible. This issue and demand can be solved by using ATEX approved products if the installation is to take place in a potentially explosive area.

When you install the communication equipment, it is important to follow the Ex standards and fulfill the requirements regarding transmitted power, cable loss, location, gain and EIRP.

Equipment in hazardous areas has to be approved due to EU standards 2014/34/EU.

It is very important to avoid the incident triggers by using the right equipment, installing certified equipment in the right location and in general fulfill the EU Ex standards. Equipment has to undergo different tests.

Product tests:

- > Impact test
- > Thermal endurance to heat and cold
- > Ingress protection IP54 test

There are also special requirements regarding installation in hazardous areas.

Installation issues:

- > Static electricity
- > Materials build up electric charges
- > Discharge can ignite an explosive atmosphere
- > Must be wiped with a damp cloth
- > Grounding – Done with a 4mm not moveable wire of stainless steel.
- > Installation – The antenna shall be installed by trained personnel in accordance with EN60079-14

Incident triggers:



- Static Electricity 22%
- Mechanical Spark 8%
- Other
- Other
- Electrical Arc and Sparks 8%

ATEX Directives:

Equipment: 2014/34/EU

Workplace: 1992/92/EC

About PROCOM A/S

PROCOM A/S is one of the leading suppliers of antenna systems for wireless 2-way radio communication for professional users. In Denmark we produce a wide range of products, which apart from antennas also comprises combiners, filters and measuring equipment.

Procom has four subsidiaries and a network of dealers covering the whole world. Procom is in close co-operation with a number of large international customers within the industry and within the public emergency forces such as Ministries of Defence, police forces, fire-fighting brigades and civil defences.

An essential part of our success in developing products for wireless 2-way radio communication is the fact that our products have the ability to tolerate an extreme load. Our organization is always ready to develop and manufacture custom-made solutions.

Procom is part of the Amphenol Corporation. Amphenol is one of the largest manufacturers of interconnect products in the world.

The company designs, manufactures and markets electrical, electronic and fiber optic connectors, coaxial and flat-ribbon cable, and interconnect systems.

The primary end markets for the company's products are communications and information processing markets, including cable television, cellular telephone and data communication and information processing systems; aerospace and military electronics; and automotive, rail and other transportation and industrial applications.



RF is our competence!

Amphenol[®]
PRIVATE NETWORKS

HEAD OFFICE AND PRODUCTION

DENMARK

PROCOM A/S
Smedetofte 12
DK - 3600 Frederikssund

Phone: +45 48 27 84 84
E-mail: info@procom.dk
www.procom.dk

UK

Amphenol Antenna Solutions
Rutherford Drive
Park Farm South,
Wellingborough, Northamptonshire
NN8 6AX United Kingdom

Phone: (+44) 1933-408408
E-mail: uk.sales@amphenol-antennas.com
www.amphenol-antennas.com

SUBSIDIARIES

FRANCE

PROCOM France SARL
Europarc
Bâtiment dénommé <<BV3>>
3, allée des Erables
FR - 94035 Creteil CEDEX

Phone: +33 (0) 149803200
E-mail: procom@procom.fr
www.procom.fr

GERMANY

PROCOM Deutschland GmbH
Heideland Süd 28
DE - 24976 Handewitt

Phone: +49 (0) 461 957722
E-mail: info@procom-deutschland.de
www.procom-deutschland.de

USA

Amphenol Antenna Solutions
1123 Industrial Drive, SW Conover
North Carolina
28613 USA

Phone: +1 402-326-7412
E-mail: ddemark@amphenol-antennas.com
www.amphenol-antennas.com